

# MTi

MINIATURE ATTITUDE AND HEADING REFERENCE SYSTEM



**xsens**

The MTi is a miniature size and low weight 3DOF Attitude and Heading Reference System (AHRS). The MTi contains accelerometers, gyroscopes and magnetometers in 3D, and as such is an Inertial Measurement Unit (IMU) as well. Its internal low-power signal processor provides real-time and drift-free 3D orientation as well as calibrated 3D acceleration, 3D rate of turn and 3D earth-magnetic field data.

The MTi is an excellent measurement unit for stabilization and control of cameras, robots, vehicles and other (un)manned equipment.

### Highlights

- Real-time computed attitude/heading and inertial dynamic data
- 360° orientation referenced by gravity and earth magnetic field
- Integrated 3D gyroscopes, accelerometers and magnetometers
- On board DSP with realtime sensor fusion algorithm
- Gyroscopes enable high-frequency orientation tracking
- High update rate (256 Hz), inertial data at max 512 Hz
- Individually calibrated for temperature, 3D misalignment and sensor cross-sensitivity
- Accepts and generates synchronization pulses

### Compact Design

- Compact and robust design
- Easy integration in any system or application (OEM)
- Low weight, ultra-low power consumption

### High performance

The MTi uses gyroscopes, accelerometers and magnetometers in order to determine the orientation. The sophisticated Xsens sensor fusion algorithm copes with temporary magnetic disturbances and short-term accelerations, resulting in a reliable real-time orientation estimate. Additionally, the MTi SDK incorporates a magnetic field mapping routine to correct for hard and soft iron effects.

### Application-specific settings for optimal accuracy

As the MTi is used in a wide range of applications, the embedded sensor fusion filter algorithm should be adapted to the specific application to ensure the best achievable accuracy. Xsens has tested and tuned the sensor fusion filter settings for a range of common motion scenarios. The unique sets

of parameters are provided in user-settable Scenarios. Using the correct scenario for your application ensures highest attainable accuracy for the application at hand, tested by Xsens, without the need for lengthy extensive tuning with uncertain results. Just set and go.

### Maximum flexibility

The MTi can be software or hardware synchronized (both SyncIn and SyncOut). The extensive SDK ensures full control of the MTi and makes interfacing to the MTi easy. The SDK provides interfaces at multiple levels: intuitive Windows GUI software, API binary libraries (Windows, Linux) as well as supplying source code implementing the MTi binary communication protocol for easy integration on any platform. With the MTi, your preferred solution is easy and fast to realize.

### Output

- 3D orientation (360°)
- 3D acceleration
- 3D rate of turn
- 3D magnetic field



## TYPICAL USAGE APPLICATIONS



### Subsurface marine

- Control and stabilization of AUV/ROV/UUV
- Orientation correction for USBL systems

The MTi will fit even in the smallest AUV/ROV/UUV, because of its small footprint. Still, it offers a remarkable accuracy in terms of orientation, dynamic data and immunity to magnetic disturbances, it has proven to be an excellent choice for small to medium sized submersibles. The on-board digital processor outputs orientation for instantaneous attitude control. The MTi can be used as a stable compass as well, using various hard- and software features. Another good example of the application of the MTi is the orientation correction for USBL systems. The direct low-level communication allows full and easy control.



### Surface Marine

- State estimation of all kinds of ships and platforms
- Orientation correction for echo sounders and sonar
- Sensor input for Dynamic Positioning (DP) systems
- Correction of sensor systems on buoys

The MTi is used for state estimation on ships, ranging from small survey vessels to large container ships. The information can be stored or displayed real-time. The MTi easily fits in small systems, such as echo sounders, sonar heads and harbour protection systems. Because of small data- packages the MTi is extremely suitable for installation in buoys to monitor orientation for long-term measurements, where storage capacity may be an issue. The MTi is also used in research concerning sea and weather dynamics.



### Unmanned ground vehicles and robotics

- Autonomous attitude control of driving and walking robots
- Control and stabilization of Unmanned Ground Vehicles (UGV)

Using the MTi in robotics is a logical choice when accurate attitude and a direct communication is mandatory. The MTi is valued for its low size and weight and can be easily configured in accordance with the user's requirements. In walking, humanoid and biped robots, the low response time of the MTi proves to be essential to provide reliable balance control. For unmanned ground vehicles, the MTi is just as useful, providing orientation and dynamic information at a very low cost. The MTi has been used by teams in all DARPA Challenges.



### Other

- Camera/antenna stabilization
- Vehicle dynamics
- Bore technology

The MTi's internal sensors provide full 3D dynamics data (acceleration and rate of turn) of any vehicle. The small size allows the MTi to be used in small-diameter pipes (under 40 mm). Together with odometry, the MTi can serve as an input to provide a full map of underground piping. The MTi can be used in many other miscellaneous applications, such as camera stabilization and antenna aiming.

## ACCESSORIES

### Cable options

#### CA-USB2



USB cable

#### CA-SERI



Serial cable  
RS232 + pigtail

#### CA-DB9i



RS232, DB9  
power

#### PA-MP



Power adapter  
(for CA-DB9i only)

## MTi DEVELOPMENT KIT

### MTi Development Kit (MTi DK)

The MTi DK contains the following:

- MTi (any configuration)
- USB cabling
- MT Software Development Kit (see below)
- Hardcopy documentation
- Optional: serial cabling
- Suitcase

### MT Software Development Kit (MT SDK)

The MT SDK is an extensive set of tools for every level of interfacing, which allows configuring the MTi to the user needs, reading out and storing data and (re-)processing MTi data previously recorded. It also allows the user to generate own source code using commands and code examples provided.

### The MT SDK contains:

#### MT Manager

An easy-to-use graphical user interface with possibilities to configure Xsens' sensors, read out, store and show data in real-time charts and visualizations.

#### MT COM-object API and DLL API for Windows

Integrating the MTi in Windows programs, such as Matlab, C++ and Excel is made easy with the MT COM-object API and the DLL API. User-modifiable example code for Matlab, C++ and Excel (VBA) is included.

#### C++ Class and binary communication for any (RT)OS

A C++ class is available for users who want to use the MTi on a binary level. Direct communication without using the C++ class is possible, following the fully documented communication protocol.

#### Magnetic Field Mapper plug-in

The Magnetic Field Mapper plug-in enables compensation for hard and soft iron effects.



**xsens**

## MTi TECHNICAL SPECIFICATIONS

### Attitude and Heading

Static accuracy (roll/pitch)	<0.5 deg
Static accuracy (heading) <sup>1</sup>	<1 deg
Dynamic accuracy <sup>2</sup>	2 deg RMS
Angular resolution <sup>3</sup>	0.05 deg
Dynamic range:	
- Pitch	± 90 deg
- Roll/Heading	± 180 deg
Maximum update rate:	
- Onboard processing	256 Hz
- External processing	512 Hz

Specified performance operating range <sup>4</sup>	0...+55 °C
--	------------

### Interfacing

Digital interface	RS-232, RS-485, RS-422 (max 921k6 bps) and USB (ext. converter)
Operating voltage	4,5 - 30V
Power consumption	350 mW
Interface options I/O	SyncOut, AnalogIn, SyncIn (depends on digital interface)

### Maximum operational limits

Ambient temperature operating range <sup>4</sup>	-40...+85 °C
--	--------------

## INDIVIDUAL SENSOR SPECIFICATIONS

### Sensor performance

Dimensions	
Full Scale (standard)	
Linearity	
Bias stability <sup>5</sup>	
Scale Factor stability <sup>5</sup>	
Noise	
Alignment error	
Bandwidth	
Max update rate	

### Rate of turn

3 axes
± 300 deg/s
0.1% of FS
1 deg/s
-
0.05 deg/s/√Hz
0.1 deg
40 Hz
512 Hz

### Acceleration

3 axes
± 50 m/s <sup>2</sup>
0.2% of FS
0.02 m/s <sup>2</sup>
0.03%
0.002 m/s <sup>2</sup> /√Hz
0.1 deg
30 Hz
512 Hz

### Magnetic field

3 axes
± 750 mGauss
0.2% of FS
0.1 mGauss
0.5%
0.5 mGauss
0.1 deg
10 Hz
512 Hz

## HARDWARE SPECIFICATIONS

### Housing

Dimensions (WxLxH)	58x58x22 mm
Weight	50 g

### Options

Interface:		Full scale acceleration:		Full scale rate of turn:
RS-232	28			150 deg/s
RS-485	48	5g (50 m/s <sup>2</sup> )	A53	300 deg/s
RS-422	68	18g (180 m/s <sup>2</sup> )	A83	1200 deg/s

Product code:	MTi-## A## G##
Standard version:	MTi-28 A53 G35

The MTi is RoHS compliant

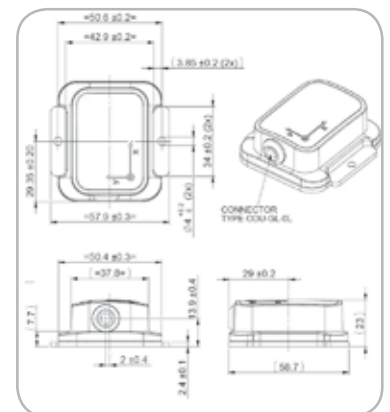

Note: Specifications subject to change without notice

- in homogeneous magnetic environment
- under condition of a stabilized Xsens sensor fusion algorithm
- 1 standard deviation of zero-mean angular random walk
- non-condensing environment
- deviation over operating temperature range 1σ



## ABOUT XSSENS TECHNOLOGIES

Xsens is a leading global supplier of 3D motion tracking products based upon miniature MEMS inertial sensor technology.

Since its inception in 2000, several thousands of motion sensors and motion capture solutions have successfully been deployed in areas such as 3D character animation, rehabilitation and sports science, and robot and camera stabilization. Customers include Electronic Arts, Sony Pictures Imageworks, INAIL Prosthesis Centre, Daimler, Saab Underwater Systems, Kongsberg Defence & Aerospace and many other companies and institutes throughout the world.

Xsens' research department has created unique intellectual property in the field of multi-sensor data fusion algorithms, combining inertial sensors with aiding technologies such as GPS and RF positioning and biomechanical modeling. The company and its products have received several awards, amongst which four consecutive entries in Deloitte's ranking of fastest growing technology companies in Europe.

Xsens is headquartered in Enschede, The Netherlands and has a subsidiary, Xsens North America Inc. in Los Angeles, California, US.

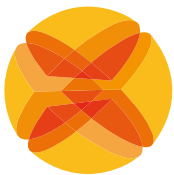

**xsens**

### **Xsens Technologies B.V.**

phone +31 88 97367 00

fax +31 88 97367 01

e-mail [info@xsens.com](mailto:info@xsens.com)

internet [www.xsens.com](http://www.xsens.com)

### **Xsens North America Inc.**

phone +1-866-973-6787 (toll-free)

fax +1-866-973-6701

e-mail [info@xsens.com](mailto:info@xsens.com)

internet [www.xsens.com](http://www.xsens.com)

© 2005-2010, Xsens Technologies B.V. All rights reserved. Information in this document is subject to change without notice. Xsens and MTi are registered trademarks or trademarks of Xsens Technologies B.V. and/or its parent, subsidiaries and/or affiliates in The Netherlands, the USA and/or other countries. All other trademarks are the property of their respective owners.